

Progressive Scan Industrial Camera Series Featuring GigE Vision Interface

GigE Vision

Cameras for Industries



Gigabit Ethernet

High speed (1Gbps) & long distance (100m) transfer
Available PoE (Power over Ethernet) Power Supply

Compatible with GigE Vision™ & GENiCAM™

Color Cameras

- KP-FD500GV** 5 Mega pixel, 9fps
- KP-FD202GV** UXGA, 30fps
- KP-FD140GV** SXGA, 30fps
- KP-FD83GV** XGA, 36fps
- KP-FD33GV** VGA, 90fps

Black & White Cameras

- KP-F500GV** 5 Mega pixel, 16fps
- KP-F202GV** UXGA, 30fps
- KP-F140GV** SXGA, 30fps
- KP-F83GV** XGA, 36fps
- KP-F33GV** VGA, 90fps



Actual Size

3CCD Color Camera

HV-F22GV SXGA, 15fps

Actual Size



GigE Vision — Main features

Speed: 1Gbps Distance: 100m



Gigabit Ethernet interface

Direct connection is possible to PC by the Gigabit Ethernet cable. This cable is less bulky compared to parallel digital output cabling. The GigE Cable length can be extended to maximum of 100m without hub and switcher

GigE Vision™ (Ver 1.00) compatible

GigE Vision, the Industrial camera interface standard, provides high speed data transmission at a maximum of 1Gbps which is highly suitable for image processing.

GENiCAM™ (Ver 1.00) compatible

Using the industrial camera control API "GENiCAM", which is supported by the European Machine Vision Association (EMVA), the development of camera control system is simplified.

PoE correspondence (except HV-F22GV)

An Ethernet cable provides Power supply (Power over Ethernet).

Direct connection to PC and triggered via Ethernet (software trigger)

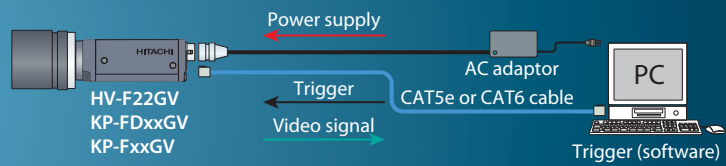

Direct connection to PC and triggered via multi-connector (Hardware trigger)

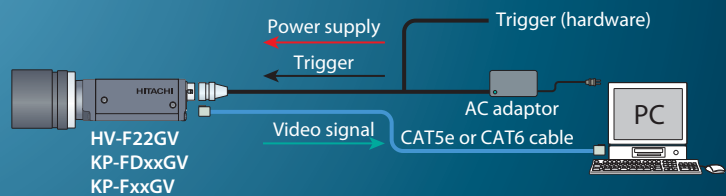

Connection via HUB/switcher to PC and power supply via the Ethernet (PoE)

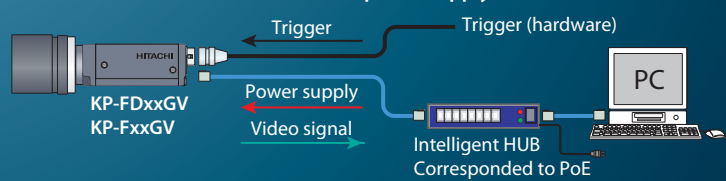

Specifications

		KP-F33GV	KP-F83G30V	KP-F140GV	KP-F202GV	KP-F500GV
Imaging device		1/3-inch progressive scan interline CCD (with on-chip microlenses)		1/2-inch progressive scan interline CCD (with on-chip microlenses)	1/1.8-inch progressive scan interline CCD	2/3-inch progressive scan interline CCD
	Total number of pixels	692(H) x 504(V)	1077(H) x 788(V)	1434(H) x 1050(V)	1688(H) x 1248(V)	2536(H) x 2068(V)
	No. of effective pixels	656(H) x 494(V)	1034(H) x 779(V)	1392(H) x 1040(V)	1628(H) x 1236(V)	2456(H) x 2058(V)
	Pixel size	7.4 μm(H) x 7.4 μm(V) (Square pixel)	4.65 μm(H) x 4.65 μm(V) (Square pixel)		4.4 μm(H) x 4.4 μm(V) (Square pixel)	3.45 μm(H) x 3.45 μm(V) (Square pixel)
Scanning area		4.88 mm(H) x 3.66 mm(V)	4.76 mm(H) x 3.57 mm(V)	6.32 mm(H) x 4.76 mm(V)	7.16 mm(H) x 5.44 mm(V)	8.47 mm(H) x 7.10 mm(V)
Scanning system		Progressive				
Sync system		Internal / external				
Lens mount		C mount				
Flange focal distance		17.526 mm				
Video output	Interface	Gigabit Ethernet				
	Protocol	GigE Vision compliant				
	Transfer rate	1 Gbit per second				
	Image format	MONO 8 / 10 / 12 bit				
	Image size	640(H) x 480(V)	1024(H) x 768(V)	1360(H) x 1024(V)	1620(H) x 1220(V)	2448(H) x 2050(V)
	Frame rate	90 frames per second	36 frames per second	30 frames per second		16 frames per second
Sensitivity		2000 lx, F11, 3200K			2000 lx, F8, 3200K	400 lx, F8, 3200K
Electric shutter speed		OFF/Auto (AES) / Manual(PRESET or VARIABLE), OFF is normal exposure(frame rate)				
	PRESET	1/90, 1/250, 1/500, 1/1000, 1/2000	1/36, 1/60, 1/125, 1/250, 1/1000, 1/4000, 1/10000, 1/50000 second	1/30, 1/60, 1/100, 1/250, 1/1000, 1/2000, 1/10000, 1/50000 second		1/16, 1/60, 1/100, 1/250, 1/1000, 1/2000, 1/10000, 1/50000 second
	VARIABLE	From 10 second to approx. 1/100000 second				
External trigger shutter	Mode	Fixed shutter. One trigger, VD Sync, Reset control				
	Input	Via Gigabit Ethernet cable (Software trigger), 12-pin connector (Hardware trigger)				
	Input level	5Vp-p ±1 V			24Vp-p ±1 V	
External sync signal	VD output	5Vp-p ±0.3 V				
	Strobe out	5Vp-p ±0.3 V				
Binning mode		OFF / ON				
Partial scan		Grabbing image area is adjustable at horizontal / vertical				
ALC (Auto level control)		Adjustable for video level				
Gain		Auto / Manual (0 dB to 18 dB)				Auto / Manual (0 dB to 12 dB)
Gamma		OFF (γ=1) / ON				
Sharpness		Adjustable				
Black level		Adjustable				
Power supply		DC+12 V ± 1V (input from 12-pin connector), 48 V (PoE)				
Power consumption		Approx. 4.0 W (DC+12 V)			Approx. 7.5 W (DC+12 V)	Approx. 7.8 W (DC+12 V)
Ambient temperature	Performance	0 °C to +40 °C / 30 to 80 %RH			0 °C to +40 °C / 90 %RH or less	
	Operating	-10 °C to +50 °C / 30 to 80 %RH			-10 °C to +50 °C / 90 %RH or less	
	Storage	-20 °C to +60 °C / 20 to 90 %RH			-20 °C to +60 °C / 70 %RH or less	
Vibration endurance		68.65 m/s ² or less(10 to 200 Hz, 30 minutes each on XYZ axes) (Do not subject to strong vibration for long periods of time.)			98.6 m/s ² or less(15 to 200 to 15 Hz, 10 minutes each on XYZ axes) (Do not subject to strong vibration for long periods of time.)	
Shock endurance		490.3 m/s ² or less (vertical, horizontal, once each face)				
External dimensions		44(W) x 29(H) x 72(D) mm(not including lens and protrusions)				
Mass		Approx. 140 g (without lens)				
Supplied equipment		Camera and CD-ROM (Operation manual / driver software)				
Optional accessories		Tripod adaptor (TA-M1), LAN cable (Enhanced category 5 or Category 6)				

1CCD Black & White / Color Models

High resolution & High Frame rate

Model	CCD	Effective pixels	Frame rate
Color (1CCD, RGB/YUV/RAW/MONO)			
KP-FD500GV	2/3	2456(H) x 2058(V)	9 fps *1
KP-FD202GV	1/1.8	1628(H) x 1236(V)	30 fps *1
KP-FD140GV	1/2	1392 (H) x 1040 (V)	30 fps *2
KP-FD83GV	1/3	1034 (H) x 779 (V)	36 fps
KP-FD33GV	1/3	656 (H) x 494 (V)	90 fps
Black & White (MONO)			
KP-F500GV	2/3	2456(H) x 2058(V)	16 fps
KP-F202GV	1/1.8	1628(H) x 1236(V)	30 fps
KP-F140GV	1/2	1392 (H) x 1040 (V)	30 fps
KP-F83GV	1/3	1034 (H) x 779 (V)	36 fps
KP-F33GV	1/3	656 (H) x 494 (V)	90 fps

*1: RAW 8bit *2: Up to SXGA (1280(H) x 960(V)) readout

High color accuracy (Color Model)

The RGB primary color mosaic filter achieves high color reproduction.

Versatile CCD drive functions

- Auto electronic Shutter mode (AES)
Adjusted automatically from 10 second to approx. 1/100,000 second.
- Preset electronic shutter mode
Multi-step up to 1/50000 second in 8 steps.
- Variable electronic shutter mode
Variable at 1H steps from 10 second to approx. 1/100,000 second.

White balance (Color Model)

- ATW : Auto-tracking white balance mode
 MANUAL : Manual white balance (R, B gain control)
 One-Push : Auto adjust function

Specifications

		KP-FD33GV	KP-FD83GV	KP-FD140GV	KP-FD202GV	KP-FD500GV
Imaging device	Total number of pixels	692(H) x 504(V)	1077(H) x 788(V)	1434(H) x 1050(V)	1688(H) x 1248(V)	2536(H) x 2068(V)
	No. of effective pixels	656(H) x 494(V)	1034(H) x 779(V)	1392(H) x 1040(V)	1628(H) x 1236(V)	2456(H) x 2058(V)
	Pixel size	7.4 μm(H) x 7.4 μm(V) (Square pixel)	4.65 μm(H) x 4.65 μm(V) (Square pixel)		4.4 μm(H) x 4.4 μm(V) (Square pixel)	3.45 μm(H) x 3.45 μm(V) (Square pixel)
	Color filter	RGB primary color mosaic filter				
Scanning area		4.88 mm(H) x 3.66 mm(V)	4.76 mm(H) x 3.57 mm(V)	6.32 mm(H) x 4.76 mm(V)	7.16 mm(H) x 5.44 mm(V)	8.15 mm(H) x 7.07 mm(V)
Scanning system		Progressive				
Sync system		Internal / external				
Lens mount		C mount				
Flange focal distance		17.526 mm				
Video output	Interface	Gigabit Ethernet				
	Protocol	GigE Vision compliant				
	Transfer rate	1 Gbit per second				
	Image format	RGB 8 / 10 / 12bit, YUV (4:2:2) 8 / 10 / 12bit, RAW 8 / 10 / 12bit, MONO 8 / 10 / 12bit				
	Image size	640(H) x 480(V)	1024(H) x 768(V)	1360(H) x 1024(V)	1620(H) x 1220(V)	2448(H) x 2050(V)
Frame rate		90 frames per second	36 frames per second	30 frames per second		9 frames per second
		*Frame rate is different for following format				
		RGB 12bit: 85 frames per second	RGB 12bit: 33 frames per second	RGB 8bit: 28 frames per second RGB 10bit: 22 frames per second RGB 12bit: 18 frames per second YUV 12bit: 28 frames per second	RGB 8bit: 18 frames per second RGB 10bit: 12 frames per second RGB 12bit: 9 frames per second YUV 8bit: 26 frames per second YUV 10/12bit: 18 frames per second	RGB 8bit: 8 frames per second RGB 10bit: 6 frames per second RGB 12bit: 4 frames per second YUV 10/12bit: 8 frames per second
Sensitivity		2000 lx, F5.6, 3200K				2000 lx, F11, 3200K
Electric shutter speed	PRESET	OFF/Auto(AES)/Manual(PRESET or VARIABLE), OFF is normal exposure(frame rate)				
	VARIABLE	1/90, 1/250, 1/500, 1/1000, 1/2000, 1/4000, 1/10000, 1/50000 second	1/36, 1/60, 1/125, 1/250, 1/1000, 1/2000, 1/10000, 1/50000 second	1/30, 1/60, 1/100, 1/250, 1/1000, 1/2000, 1/10000, 1/50000 second		1/9, 1/60, 1/100, 1/250, 1/1000, 1/2000, 1/10000, 1/50000 second
External trigger shutter	Mode	Fixed shutter, One trigger, VD Sync, Reset control				
	Input	Via Gigabit Ethernet cable (Software trigger), 12-pin connector (Hardware trigger)				
External sync signal	Input level	5 Vp-p ±1 V				
	VD output	5 Vp-p ±0.3 V				
Partial scan	Strobe out	5 Vp-p ±0.3 V				
		Grabbing image area is adjustable at horizontal / vertical				
ALC (Auto level control)		Adjustable for video level				
White balance		ATW/MANUAL/One-push				
Gain		Auto / Manual (0dB to 18dB)				Auto / Manual (0dB to 12dB)
Gamma		OFF (γ=1) / ON				
Color masking		OFF/ON (6 color independent masking)				
Paint black		Adjustable				
Sharpness		Adjustable				
Black level		Adjustable				
Knee		Adjustable				
Power supply		DC+12 V plus minus 1 V (input from 12-pin connector), 48 V (PoE)				
Power consumption		Approx. 4.5 W (DC+12 V)		Approx. 7.8 W (DC+12 V)		Approx. 7.5 W (DC+12 V)
Ambient temperature	Performance	0 °C to +40 °C / 30 to 80 %RH			0 °C to +40 °C / 90 %RH or less	
	Operating	-10 °C to +50 °C / 30 to 80 %RH			-10 °C to +50 °C / 90 %RH or less	
	Storage	-20 °C to +60 °C / 20 to 90 %RH			-20 °C to +60 °C / 70 %RH or less	
Vibration endurance		68.65 m/s ² or less(10 to 200 Hz, 30 minutes each on XYZ axes) (Do not subject to strong vibration for long periods of time.)			98.6 m/s ² or less(15 to 200 to 15 Hz, 10 minutes each on XYZ axes) (Do not subject to strong vibration for long periods of time.)	
Shock endurance		490.3 m/s ² or less (vertical, horizontal, once each face)				
External dimensions		44(W) x 29(H) x 72(D) mm (not including lens and protrusions)				
Mass		Approx. 140 g (without lens)				
Supplied equipment		Camera and CD-ROM (Operation manual / driver software)				
Optional accessories		Tripod adaptor (TA-M1), LAN cable (Enhanced category 5 or Category 6)				



Lens: option

6 color independent masking (Color Model)

Saturation and hue of primary colors R, G, B and complementary colors Cy, Mg, Ye can be independently varied. It is effective for many applications (Image capture, microscope, etc) needing accurate color reproduction.

External trigger

An external trigger signal input can be used to capture an image at desired timing for instant view or processing. The software trigger using a Gigabit Ethernet cable and the hardware trigger can deal with all trigger signals.

Versatile output image format (Color Model)

The output format can be selected
 RGB 8 / 10 / 12bit, YUV (4:2:2) 8 / 10 / 12bit, RAW 8 / 10 / 12bit or MONO 8 / 10 / 12bit.

3CCD Color Model

HV-F22GV 1/2, 1360 (H) x 1024 (V), 15 fps

High resolution

The 1/2-inch / 1.45 Mega pixels square lattice progressive scan CCD (R. G. B. 3CCD) and highly precise CCD positioning technology results in high resolution of 1360(H) x 1024(V) (SXGA).

High Precision digital Processing

The single chip 3 million gates 0.18µm DSP design reduces the size, power consumption and greatly enhances stability. The 12 bit A/D converter and 14bit DSP processing provide a high S/N ratio and wide dynamic range.



Lens: option

High color reproduction and resolution

The 3 CCD (R. G. B) and prism system provide accurate color reproduction and high resolution.

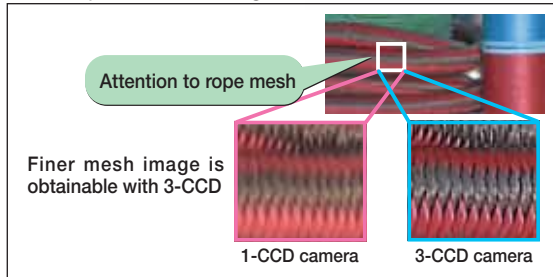

Easy to use GUI software

Various camera functions are available for adjustment through the easy-to-use GUI software which is included with the camera.

Application menu

MAIN	BRIGHTNESS	MASKING
	SHARPNESS	B/W
	WHITE BALANCE	(BLACK BALANCE & WHITE GATE)
	GAIN	AUTO EXPOSURE
	SHUTTER	SHARPNESS
	AUTO EXPOSURE	OTHER FUNC
	SATURATION	Focus detection
	GAMMA	
	TRIGGER	
	FLASH	
	AUTO SHADING	

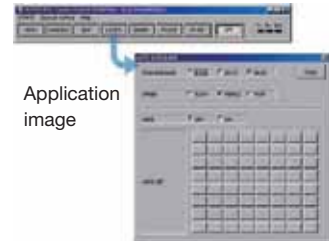

6 color independent masking

Saturation and hue of primary colors R, G, B and complementary colors Cy, Mg, Ye can be independently varied. It is effective for an applications (Image capture, microscope, etc) needing highly accurate color hue.

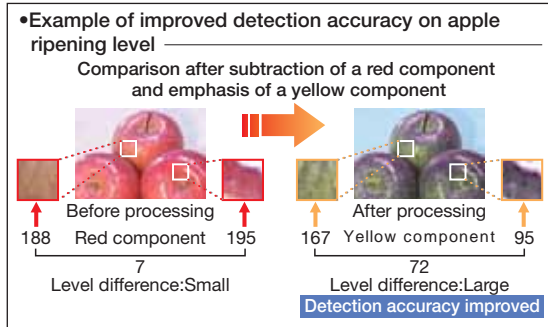

Adjustable Sharpness (DTL) width

Sharpness (DTL) width is adjustable. Natural definition is provided when setting a sharpness lower. A clear detail is provided when setting it higher.

Auto Shading (ASC)

Color shading (uneven color) due to lens and lighting can be automatically corrected.

Versatile CCD driving function

- External Trigger function
- Long time accumulate mode
- Variable shutter mode
- Automatic electronic shutter mode (AES)

Improved operation

- Provides 4 application files
- Realtime automatic white balance function (ATW)
- Automatic Exposure (ALC)(Automatic level control) (Digital light measuring utilizing a scene divided into 64 sensing areas)
- Focus data output (serial data)
- 2 mode gain control(AGC function, 1 dB step programmable gain control)
- Contrast function
- Flare correction circuit
- Brightness (master black), R/B black, R/B gain adjustment function
- Color bar function
- Neg/pos switching function
- Rear LED indicator (Power on/off, communication state)

Specifications

		HV-F22GV
Imaging device	Total number of pixels	1434(H) x 1050(V)
	No. of effective pixels	1360(H) x 1024(V)
	Pixel size	4.65 µm(H) x 4.65 µm(V) (Square pixel)
	Optical system	1/2-inch F1.6 prism
Scanning area		6.32 mm(H) x 4.76 mm(V)
Scanning system		Progressive
Sync system		Internal / external (HD/VD automatically switch)
Lens mount		C mount
Flange focal distance		17.526 mm
Video output	Interface	Gigabit Ethernet
	Protocol	GigE Vision compliant
	Transfer rate	1 Gbit per second
	Image format	RGB 8 bit
	Image size	1360(H) x 1024(V)
	Frame rate	15 frames per second
Sensitivity		2000 lx, F8 (at 1/30 second shutter)
Electric shutter speed	Variable	Auto(AES) / Variable / Accumulate mode
	AES	1/15 to 1/100,000 second
	Accumulate	1/15 to 4 second (1 frame step)
External trigger shutter	Mode	Fixed shutter, One trigger
	Input	Via Gigabit Ethernet cable (Software trigger) or 12-pin connector (Hardware trigger)
	Input level	Low: 0 V DC, High: 3 to 24 V DC
External sync signal (Strobe out)		5 Vp-p ±0.3 V
Screen distortion		All Screen: 0% (except lens characteristics)
Registration		All Screen: 0.05% (except lens characteristics)
Vertical Sharpness		2 H
White balance		ATW / MANUAL / One-push
Gain		AGC (0 to +12 dB) or 1dB step
Gamma		0.45 / 1.0 (ON / OFF)
Color masking		OFF/ON(6 color independent masking)
Sharpness		Sharpness (DTL) level, Sharpness (DTL) width
Color bar		Full
Power supply		DC+12 V (10.5 V to 15 V DC without ripple)
Power consumption		Approx. 9.0 W (DC+12 V)
Ambient temperature	Operating	0 °C to +40 °C
	Storage	-20 °C to +60 °C
Vibration endurance		24.5 m/s ² or less (10 to 200 Hz, 30 minutes each on XYZ axes) (Do not subject to strong vibration for long periods of time.)
Shock endurance		392 m/s ² or less (vertical, horizontal, once each face)
External dimensions		65(W) x 65(H) x 141(D) mm (not including lens and protrusions)
Mass		Approx. 600 g (without lens)
Supplied equipment		Camera, Lens mount sheet, DC IN / SYNC connector plug (HR10A-10P-12S) and CD-ROM (driver software) and Instruction manual
Optional accessories		LAN cable (Enhanced category 5 or Category 6)

Dimensions

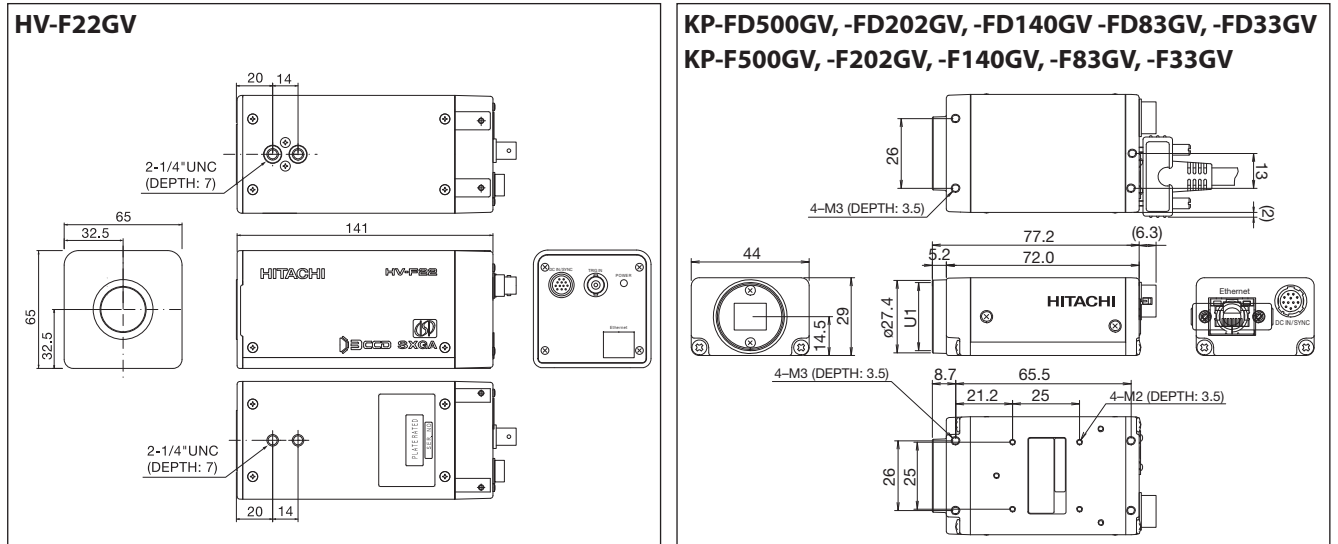

Rear View

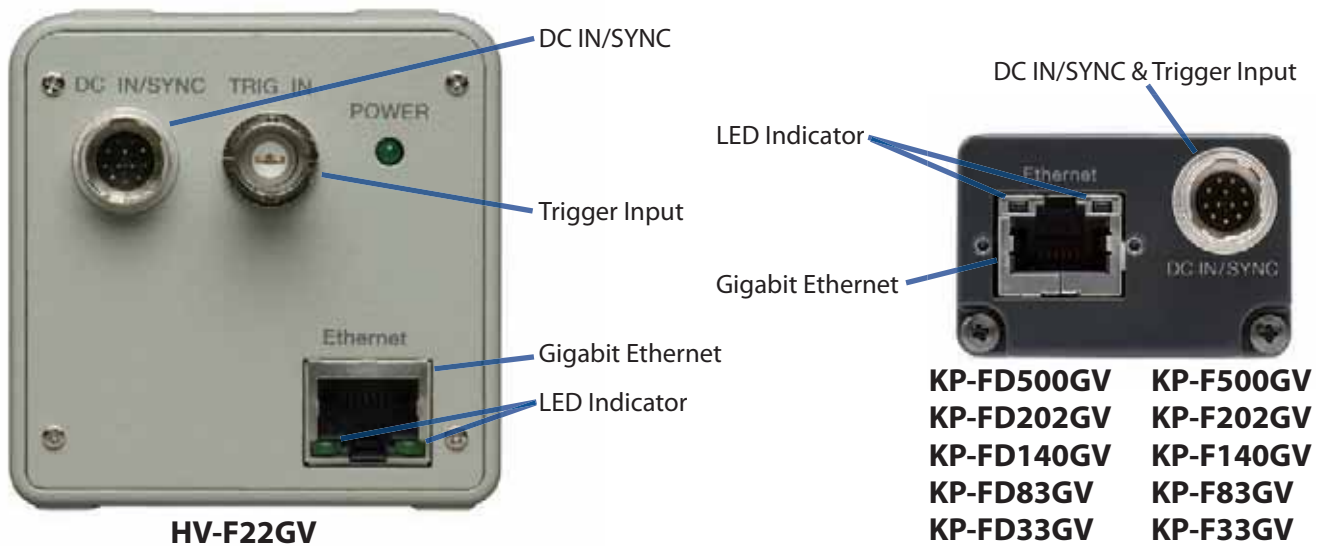

Accessories

Type		Black and White	Color	3CCD
	Model Name	KP-F500GV KP-F202GV KP-F140GV KP-F83GV KP-F33GV	KP-FD500GV KP-FD202GV KP-FD140GV KP-FD83GV KP-FD33GV	HV-F22GV
Tripod Adaptor	TA-M1			
Camera Cable	(2m)	C-201KSM		
	(5m)	C-501KSM		
	(10m)	C-102KSM		
12 Pin Plug	HR10A-10P-12S			
Dummy Glass	ARC1214	*1		
IR-Cut Filter	IRC650		*2	*2



TA-M1



C-201KSM

*1: ARC1214 is equipped in the KP-F type camera.

*2: IRC650 is equipped in the KP-FD/HV-F type camera.

Hitachi Industrial Progressive Scan Camera Line-up

		Image Size						
		VGA	XGA	SXGA	UXGA	5.0M		
Frame rate	120fps	(RAW) KP-FR31PCL/SCL (B/W) KP-F31PCL/SCL	(3CCD) : 3CCD output (RGB) : RGB Output (RAW) : RAW Data Output (B/W) : Monochrome Output GigE Vision Series KP-FD type can select the output image format (RGB/YUV/RAW/MONO)		GV : GigE Vision PCL : Power over Camera Link SCL : Mini Camera Link CL : Camera Link F : IEEE1394.a/b			
	91fps	(RAW) KP-FR39PCL/SCL (B/W) KP-F39PCL/SCL						
	90fps	(RGB) KP-FD33GV (B/W) KP-F33GV						
	60fps	(RGB) KP-FD32F (RAW) KP-FR30PCL/SCL (RAW) KP-FBR30PCL/SCL (B/W) KP-F30PCL/SCL (B/W) KP-F32F (B/W) KP-FB30PCL/SCL					(3CMOS)HDTV 720P (920K) HV-HD30	
	36fps	(RGB) KP-FD83GV (B/W) KP-F80PCL/SCL (B/W) KP-F83GV (RAW) KP-FR80PCL/SCL						
	30fps	(3CCD)HV-F31CL (B/W) KP-F83F					(RGB) KP-FD140GV (RGB) KP-FD140PCL/SCL (B/W) KP-F140GV	(RGB) KP-FD202PCL/SCL (RAW) KP-FR230PCL/SCL (B/W) KP-F230PCL/SCL (B/W) KP-F202GV (RGB) KP-FD202GV
	16fps							(RAW) KP-FR500PCL/SCL (B/W) KP-F500PCL/SCL (B/W) KP-F500GV
	15fps	(3CCD)HV-F31F					(3CCD)HV-F22GV (3CCD)HV-F22CL (RGB) KP-FD140F (B/W) KP-F140F	(RAW) KP-FR200PCL/SCL (B/W) KP-F200PCL/SCL
	12fps							(RGB) KP-FD500PCL/SCL
	9fps							(RGB) KP-FD500GV
7.5fps		(3CCD)HV-F22F						



KP-FD500/FR500/F500P(S)CL
KP-FD202/FD140P(S)CL
44x44x41mm



KP-FR200/F200P(S)CL
KP-FR80/F80P(S)CL
KP-FR39/F390P(S)CL
KP-FR30/F30P(S)CL
29x29x29mm



KP-FR230/F230P(S)CL
KP-FR31/F31P(S)CL
29x29x38mm



KP-FBR30/FB30P(S)CL
Head 12x12.5x47.5mm
CCU 29x29x38mm

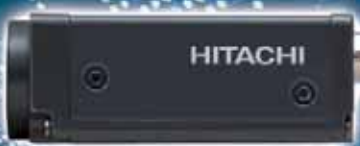

KP-FD500/F500GV
KP-FD202/F202GV
KP-FD140/F140GV
KP-FD83/F83GV
KP-FD33/F33GV
44x29x72mm



HV-F22GV
65x65x141mm
HV-F22/F31CL
HV-F22/F31F
65x65x130mm

GigE Vision™ and the distinctive logo and Camera Link® are trademarks of the AIA (Automated Imaging Association). GENiCAM™ is trademark of the EMVA (European Machine Vision Association). Ethernet is a trademark of Xerox Corporation USA.

CAUTION: To ensure safe operation, Please read the instruction manual before using this product.

Hitachi Kokusai Electric Inc.

Head Office: AKIHABARA UDX Bldg, 11F, 4-14-1 Sotokanda 4-choume, Chiyoda-ku, Tokyo 101-8980, Japan
Phone: +81 (0) 3-6734-9432 Fax: +81 (0) 3-5209-5942

Hitachi Kokusai Electric America, Ltd. URL: <http://www.hitachikokusai.us>

Head Quarters and: 150 Crossways Park Drive, Woodbury, New York 11797, U.S.A.

Northeast Office: Phone: +1 310-328-6116 Fax: +1 516-496-3718

West Office: 371 Van Ness Way, Suite 120 Torrance, CA, 90501

Phone: +1 330-334-4115 Fax: +1 516-496-3718 Service: +1 989-345-5379

Midwest Sales: Phone: +1 850-934-1234 Fax: +1 516-496-3718 Service: +1 256-774-3777

Latin Sales: Phone: +1 516-882-4408 Fax: +1 516-496-3718

Parts Center: Phone: +1 516-882-4435 Fax: +1 516-921-0993

Hitachi Kokusai Electric Canada, Ltd. URL: <http://www.hitachikokusai.ca>

Head Office: 1 Select Avenue, Unit #12, Scarborough, Ontario M1V, 5J3, Canada

Phone: +1 416-299-5990 Fax: +1 416-299-0450

Eastern Office: 5795 Chemin St. Francois St. Laurent, Quebec H4S, 1B6, Canada

Phone: +1 514-332-6687 Fax: +1 514-335-1664

Hitachi Kokusai Electric Europe GmbH URL: <http://www.hitachi-keu.com>

Head Office: Gruitener Str.3, D-40699 Erkrath, Germany

Phone: +49(0) 2104-96550 Fax: +49(0) 2104-40039

Frankfurt Office: Siemensstr.9, D-63263 Neu-Isenburg, Germany

Phone: +49(0) 6102-83320 Fax: +49(0) 6102-202616

General email address: info@hitachi-keu.com

Hitachi Kokusai Electric U.K. Ltd.

Head Office: Windsor House, Queensgate, Waltham Cross, Herts, EN8 7NX, United Kingdom

Phone: +44(0) 845-121-2177 Fax: +44(0) 845-121-2180

General email address: info@hitachi-keu.com

Hitachi Kokusai Electric (Shanghai) Co., Ltd.

Beijing Branch: Room 1415, Beijing Fortune Building, 5 Dong San Huan Bei-Lu, Chao Yang District, Beijing 100004

Phone: +86(0) 10-6590-8755/8756 Fax: +86(0) 10-6590-8757

Beijing Service: A25, Bei San Huan Zhong Road Chao Yang District, Beijing 100029

Phone: +86(0) 10-6204-3901/3903 Fax: +86(0) 10-6204-3902

Center

These Specifications are subject to change without notice.



CERTIFICATE No.
JMI-0062
ISO 9001/BS 5750Pt1
EN 29001/JIS Z9901