



sCMOS

Scientific CMOS Technology

A High-Performance Imaging Breakthrough

5.5 Megapixel sCMOS
100 frames/sec

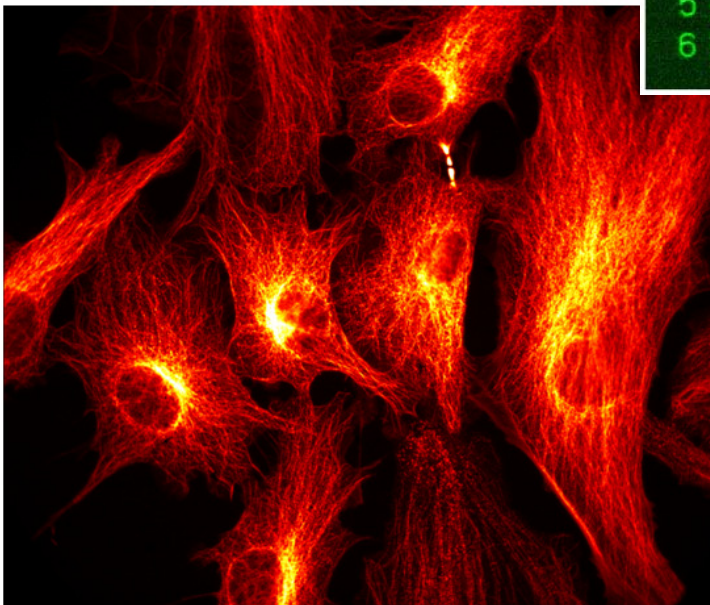

sCMOS – 1.5 e⁻ noise

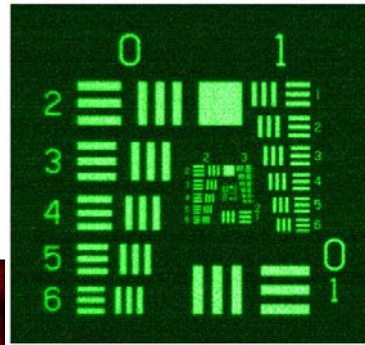

Interline CCD – 5 e⁻ noise

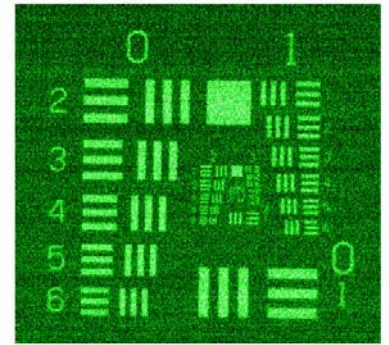

1.3 Megapixel interline
11 frames/sec

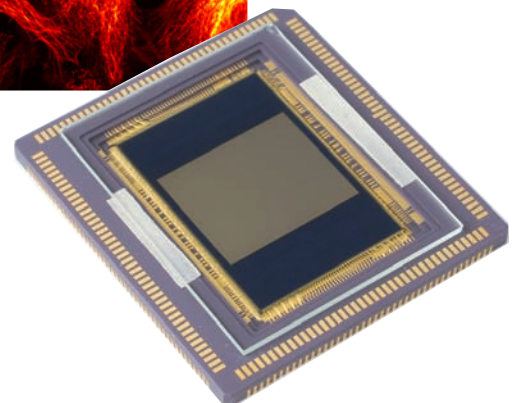
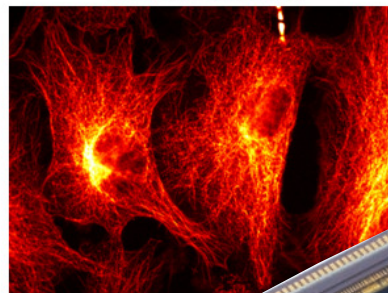

White Paper : Dr. Colin Coates, Andor Technology
Dr. Boyd Fowler, Fairchild Imaging
Dr. Gerhard Holst, PCO AG
16 June 2009
www.scmoss.com

Contents

1 - Today's Imaging Detectors.....	Pg 3
1.1 - CCDs and EMCCDs.....	Pg 3
1.2 - CMOS Imaging Sensors (CIS).....	Pg 5
1.3 - Hybrid CCD/CMOS Image Sensors.....	Pg 5
2 - Scientific CMOS Technology.....	Pg 6
2.1 - sCMOS - A new breed of scientific CIS.....	Pg 6
2.2 - No compromise.....	Pg 6
2.3 - Insight into the sCMOS architecture.....	Pg 7
2.4 - Rolling vs Global (Snapshot) shutter modes.....	Pg 9
2.5 - sCMOS compared to other leading scientific imaging technologies.....	Pg 9
Summary.....	Pg 14

Introduction

Since its inception, CMOS image sensor (CIS) technology has held great potential to become the detector platform of choice for many scientific imaging applications. These demanding fields require a unique combination of sensitivity, speed, dynamic range, resolution, and field of view.

Although CIS technology has steadily improved it has not fully realized its potential, with CCD, and more recently EMCCD, detectors remaining the platforms of choice for the majority of high-end scientific imaging applications.

In this paper we present sCMOS, a breakthrough technology based on next-generation CIS design and fabrication techniques. sCMOS is poised for widespread recognition as a true scientific grade CIS, capable of out-performing most scientific imaging devices on the market today.

Unlike previous generations of CMOS and CCD-based sensors, sCMOS is uniquely capable of **simultaneously** offering:

- Extremely low noise
- Rapid frame rates
- Wide dynamic range
- High quantum efficiency (QE)
- High resolution
- Large field of view

1 - Today's Imaging Detectors

1.1 - CCDs and EMCCDs

Many scientific imaging applications demand multi-megapixel focal plane sensors that can operate with very high sensitivity and wide dynamic range. Furthermore, it is often desirable that these sensors are capable of delivering rapid frame rates in order to capture dynamic events with high temporal resolution. Often there is a strong element of mutual exclusivity in these demands. For example, it is feasible for CCDs to achieve less than 3 electrons RMS readout noise, but due to the serial readout nature of conventional CCDs, this performance comes at the expense of frame rate. This is especially true when the sensor has several megapixels of resolution. Conversely, when CCDs are pushed to faster frame rates, resolution and field of view are sacrificed (i.e. fewer pixels per frame to read out) or read noise and dynamic range suffer.

By way of illustration, consider one of the most popular, high-performance front-illuminated scientific CCD technologies on the market today – the interline CCD. These devices are capable of reading out at 20Mpixel/s per output port with a respectable read noise of only 5 to 6 electrons RMS. At this readout speed a single port 1.3 megapixel sensor can achieve 11 frames/s. Use of microlenses ensures that most of the incident photons are directed away from the interline metal shield and onto the active silicon area for each pixel resulting in peak QE greater than 60%.

High performance combined with low cost, has made the interline CCD a very popular choice for applications such as fluorescence cell microscopy, luminescence detection and machine vision. However, even 5 to 6 e⁻ noise is too high for many low light scientific applications. For example, when imaging the dynamics of living cells, there is a need to limit the amount of fluorescence excitation light, such that both cell mortality and photobleaching of the fluorescent dyes is minimized.

The use of lower power excitation results in a proportionally lower fluorescent emission signal from the cell. Also dynamic imaging yields shorter exposure times per frame, thus fewer photons per frame.

Ultra low light conditions mean that the read noise floor can often become the dominant detection limit, seriously compromising the overall signal-to-noise ratio (SNR) and hence the ability to contrast fine structural features within the cell. As such, the inability to maintain low noise at faster readout speeds limits the overall flexibility of the interline CCD camera. The Electron Multiplying CCD (EMCCD) was introduced into the market in 2000 and represented a significant leap forward in addressing the mutual exclusivity of speed and noise as discussed above.

EMCCD cameras employ an on-chip amplification mechanism called 'Impact Ionization' that multiplies the photoelectrons that are generated in the silicon. As such, the signal from a single photon event can be amplified above the read noise floor, even at fast, multi-MHz readout speeds. Importantly, this renders the EMCCD capable of single photon sensitivity at fast frame rates (e.g. 30 frames/s with a 512x512 array).

This attribute has rapidly gained recognition for EMCCD technology in demanding low light measurements, such as single molecule detection. However, despite the sensitivity under extremely low light conditions, there are a few remaining drawbacks of EMCCD technology. The amplification mechanism required to reduce the effective read noise to < 1e⁻, also induces an additional noise source called multiplicative noise.

Applications of sCMOS include:

- Live cell microscopy
- Particle Imaging Velocimetry (PIV)
- Single molecule detection
- Super resolution microscopy
- TIRF microscopy / waveguides
- Spinning disk confocal microscopy
- Genome sequencing (2nd and 3rd gen)
- FRET
- FRAP
- Lucky astronomy / imaging
- Adaptive optics
- Solar astronomy
- Fluorescence spectroscopy
- Bio- & Chemi - luminescence
- High content screening
- Photovoltaic inspection
- X-ray tomography
- Ophthalmology
- Flow cytometry
- Biochip reading
- Machine vision
- TV / Broadcasting
- Spectral (hyperspectral) imaging
- Laser Induced Breakdown Spectroscopy (LIBS)

This effectively increases the RMS shot noise of the signal by a factor of 1.41, which is manifested in the imagery as an increase in the pixel to pixel and frame to frame variability of low light signals. The net effect of multiplicative noise is that the acquired image has a diminished signal-to-noise ratio, to an extent that the QE of the sensor can be thought to have been effectively reduced by a factor of two. For example, a QE-enhanced back-illuminated EMCCD with 90% QE has effectively 45% QE when the effects of multiplicative noise are considered.

Dynamic range limitations of EMCCDs must also be considered. It is possible to achieve respectably high dynamic range with a large pixel (13 to 16µm pixel size) EMCCD, but only at slow readout speeds.

As such, higher dynamic range can only be reached at slower frame rates (or with reduced array size) with modest EM gain settings. Application of higher EM gain settings results in the dynamic range being depleted further. Sensor cost of EMCCD technology is an additional consideration, along with the practical restriction on resolution and field of view that accompanies sensor cost. Presently, the largest commercially available EMCCD sensor is a back-illuminated 1024 x 1024 pixel device with 13µm pixel pitch, representing a 13.3 x 13.3mm sensor area. This already carries a significant cost premium, making further expansion to multi-megapixel devices a costly proposition.

Furthermore, in order to maintain a respectably fast frame rate from multi-megapixel EMCCDs, multi-port readout architecture will need to be implemented, which itself carries a cost premium. Finally, EMCCD sensors require considerable power consumption to operate, and often a reasonable degree of thermoelectric cooling is needed to render them effective, making EMCCD technology impractical for several specific low light imaging applications for which this is a factor.

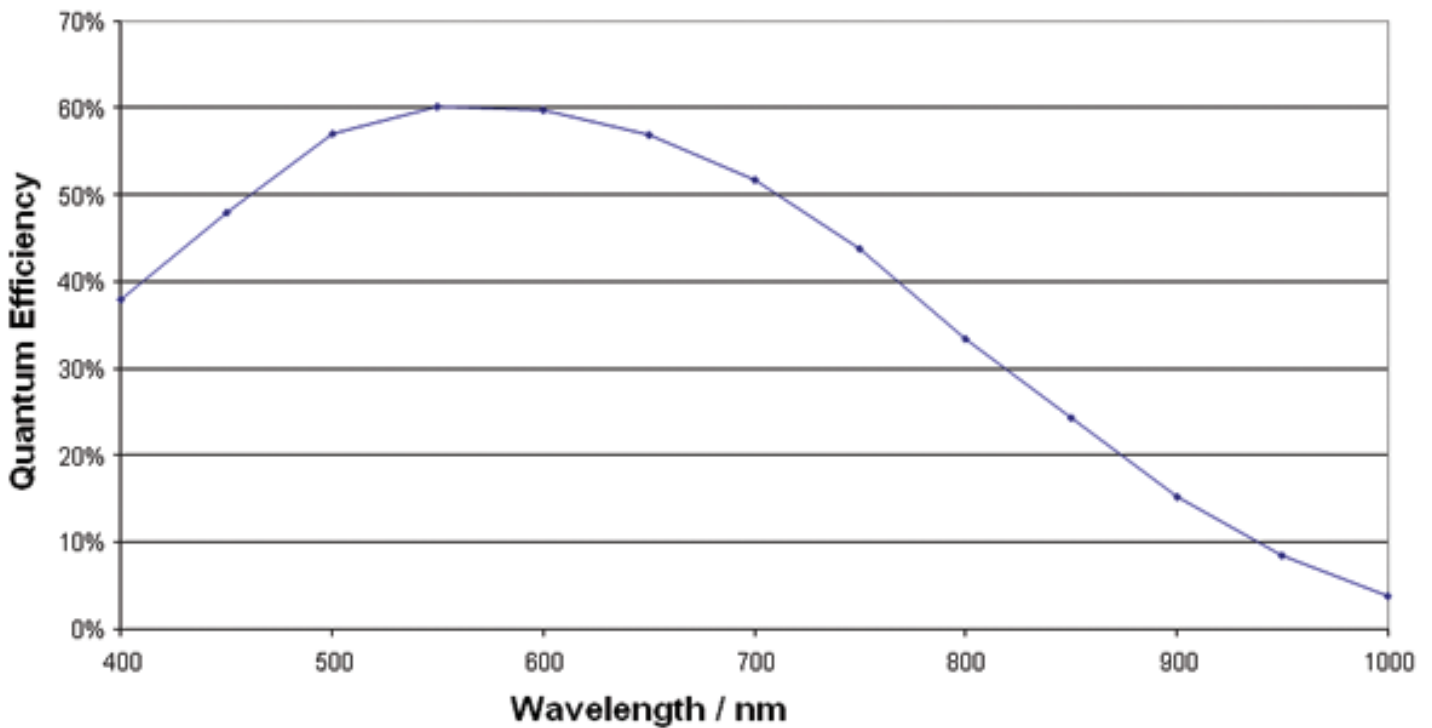

Figure 1: QE curve between 400 – 1000nm of front-illuminated (microlens) sCMOS sensor. Note that both green and red/NIR response is well enhanced.

1.2 - CMOS Imaging Sensors (CIS)

CMOS image sensors are similar to CCD sensors, in so far as they are semiconductor devices with photosensitive areas in each pixel that convert incident photons into electrons. Although CMOS image sensor technology was developed in the 1960's, CCDs have dominated the image sensor market since the early 1970's. It was not until the mid-90s that serious attention has once again focused on CMOS image sensor development. This work was fuelled largely by the increasingly sophisticated imaging demands of high-volume consumer markets such as camcorders, digital still cameras, cellular phones, machine vision and automotive.

In addition, improvements in CMOS fabrication processes rapidly enabled CIS to gain ground on CCDs in many areas including speed and readout noise.

Broadly speaking however, and despite some undeniably rapid advances over the last decade, 'traditional' CIS performance has generally been worse than CCDs and their acceptance into scientific markets has been limited due to a reputation of unacceptably high read noise and dark current, lower fill factors, and greater non-uniformity.

These are all drawbacks that our new sCMOS technology has been specifically designed to overcome.

1.3 - Hybrid CCD/CMOS Image Sensors

Over the past five to six years, some amount of development effort has gone into the design and manufacture of hybrid CCD/CMOS devices. These have been conceived in order to match the traditionally high fidelity imaging performance of CCDs with the readout speed capabilities of CMOS.

A hybrid focal plane array is comprised of CMOS Readout Integrated Circuits (ROICs) that are bump bonded to a CCD imaging substrate. By applying a column-parallel readout architecture, the speed versus noise limitations of a conventional CCD can be overcome.

The primary issues with hybrid technology are the expense of design and fabrication, and noise limitation caused by the silicon to silicon bump capacitance.

As will be shown on the next page, sCMOS technology is now able to deliver everything that hybrid CCD/CMOS technology promised to deliver and more, rendering the latter technology less desirable, due to unnecessary complexity and expense.

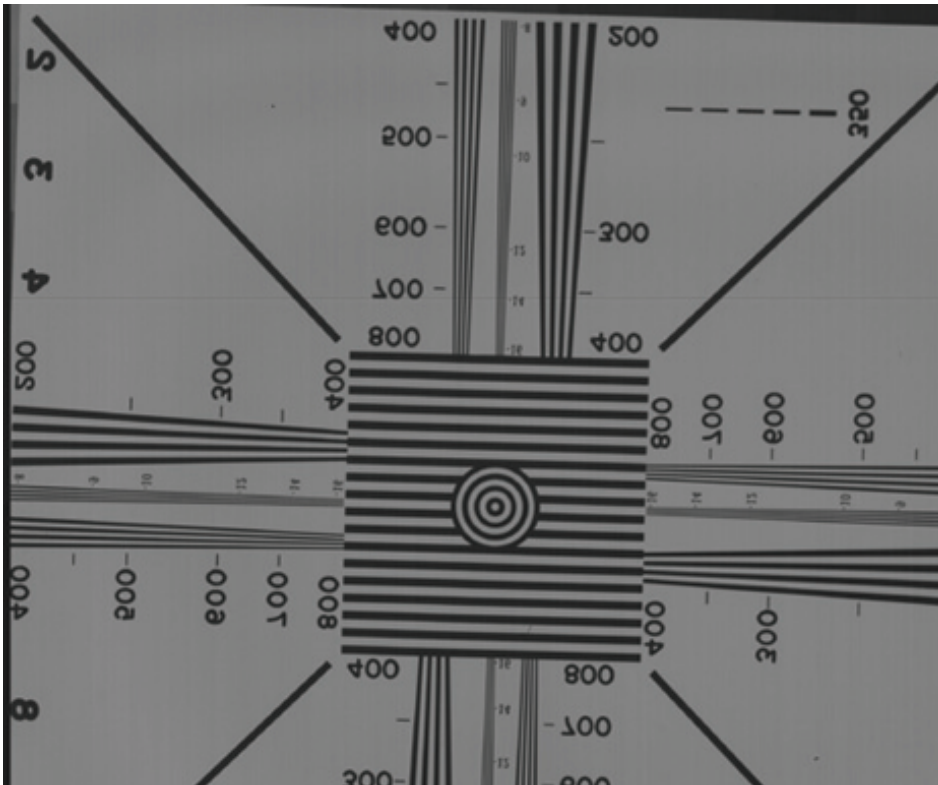

Figure 2: First image taken with the new 5.5 Megapixel sCMOS sensor

2 - Scientific CMOS Technology

2.1 - sCMOS - A new breed of scientific CIS

Recently, we have pioneered a breakthrough imaging sensor technology that is based on a new generation of CMOS design and process technology. This device type carries an advanced set of performance features that renders it entirely suitable to high fidelity, quantitative scientific measurement. Scientific CMOS (sCMOS) can be considered unique in its ability to simultaneously deliver on many key performance parameters, overcoming the ‘mutual exclusivity’ that was earlier discussed in relation to current scientific imaging technology standards, and eradicating the performance drawbacks that have traditionally been associated with conventional CIS.

By way of comparison, the lowest noise interline CCD, reading out only 1.3 megapixels at ~ 16 frames/s would do so with ~ 10 electrons read noise.

Greater speed is available through selection of ‘region of interest’ sub-windows, such that the field of view can be traded off to achieve extreme temporal resolution. Table 1 below shows frame rates that can be expected from a series of sub-window sizes, in both rolling shutter and global shutter modes of operation (the distinction between these two modes is explained later in this paper). Note that each of the sub-windows can be expanded to full width in the horizontal direction and still maintain the same indicated frame rate. For example, both 1300x1024 and 2560x1024 sub-window sizes each offer 220 frames/s

The low noise readout is complemented by a high dynamic range of > 16:000:1. Usually, for CCDs or EMCCDs to reach their highest dynamic range values, there needs to be a significant compromise in readout speed, yet sCMOS can achieve this value while delivering 30 frames/s.

Furthermore, the architecture of sCMOS allows for high dynamic range by offering a large well depth, despite the small pixel size. By way of comparison, a 1.3 megapixel interline with similarly small pixels achieves only ~1800:1 dynamic range at 16 frames/s.

Performance highlights of the first sCMOS technology sensor include:

Sensor format	5.5 megapixels 2560 (h) x 2160 (v)
Read noise	< 2 e ⁻ rms @ 30 frames/s; < 3 e ⁻ rms @ 100 frames/s
Maximum frame rate	100 frames/s
Pixel size	6.5 μm
Dynamic range	16,000:1 @ 30 frames/sec
QE_{max}	60%
Read out modes (User selectable)	Rolling and Global Shutter

2.2 - No compromise

The 5.5 megapixel sensor offers a large field of view and high resolution, without compromising read noise or frame rate. The read noise in itself is exceptional, even when compared to the highest performance CCDs. Only slow-scan CCDs are capable of this level of read noise performance. High-resolution, slow-scan CCDs are typically characterized by seconds per frame rather than frames per second. The fact that the sCMOS device can achieve < 2 electrons RMS read noise while reading out 5.5 megapixels at 30 frames/s renders it truly extraordinary in the market. Furthermore, the sensor is capable of achieving 100 full frames/s with a read noise < 3 electrons RMS.

in rolling shutter mode. This is important information for some applications that can take advantage of an elongated (letter box shape) region of interest.

Array Size (H x V)	Rolling Shutter mode (frames per second)	Global Shutter mode (frames per second)
2560 x 2160 (full frame)	105	52.5
2048 x 2048 (4 megapixel)	110	55
1300 x 1024 (1.3 megapixel)	220	110
512 x 512	440	220
256 x 256	880	440
128 x 128	1760	880

Table 1: Frame rate vs sub-window size; Rolling and Global shutter readout modes. N.B. Same sub-window frame rates apply when using full horizontal width with the vertical heights indicated (see body text for further detail).

2.3 - Insight into the sCMOS architecture

While the primary technical advancements that underlie this innovation must remain proprietary, some of the architectural detail can be disclosed in the interests of further understanding.

The sensor features a split readout scheme in which the top and bottom halves of the sensor are read out independently. Each column within each half of the sensor is equipped with dual column level amplifiers and dual analog-to-digital converters (ADC), represented as a block diagram in Figure 3. This architecture was designed to minimize read noise and maximize dynamic range simultaneously.

The dual column level amplifier/ADC pairs have independent gain settings, and the final image is reconstructed by combining pixel readings from both the high gain and low gain readout channels to achieve a wide intra-scene dynamic range from such a small pixel pitch.

Each pinned-photodiode pixel has 5 transistors ('5T' design), enabling the novel 'global shutter' mode (described in more detail below) and also facilitating correlated double sampling (CDS) and a lateral anti-blooming drain.

The sensor is integrated with a microlens array that serves to focus much of the incident light per pixel away from the transistors and onto the exposed silicon, enhancing the QE (analogous to use of microlenses in interline CCDs to focus light away from the column masks).

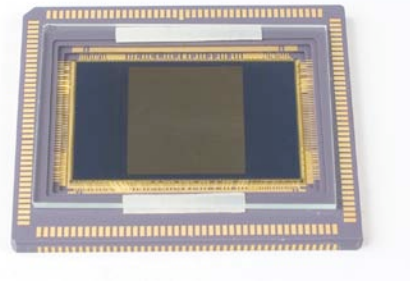

Figure 4: The 5.5 Megapixel sCMOS sensor

The sensor is configured to offer low dark current and extremely low read noise with true CDS. Non-linearity is less than 1% and is further correctable to < 0.2%.

The sensor also has anti-blooming of >10,000:1, meaning that the pixels can be significantly oversaturated without charge spilling into neighboring pixels. It is also possible to use the anti-blooming capability to hold all or parts of the sensor in a state of 'reset', even while light is falling on these pixels. The time to transfer charge after the exposure is complete is less than 1µs, rendering the sensor useful for fast electronic shuttering and 'double exposure' techniques such as Particle Imaging Velocimetry (PIV).

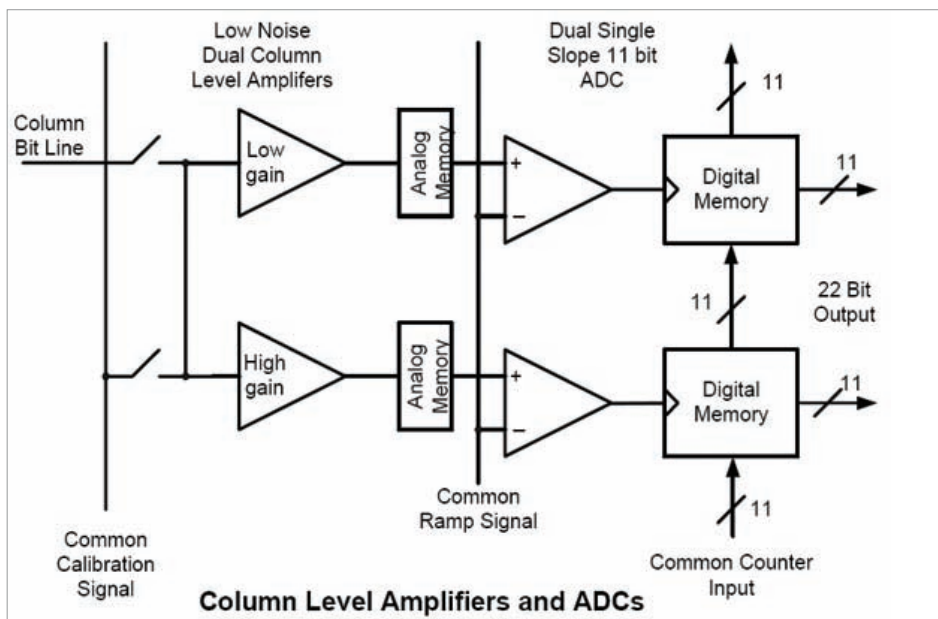
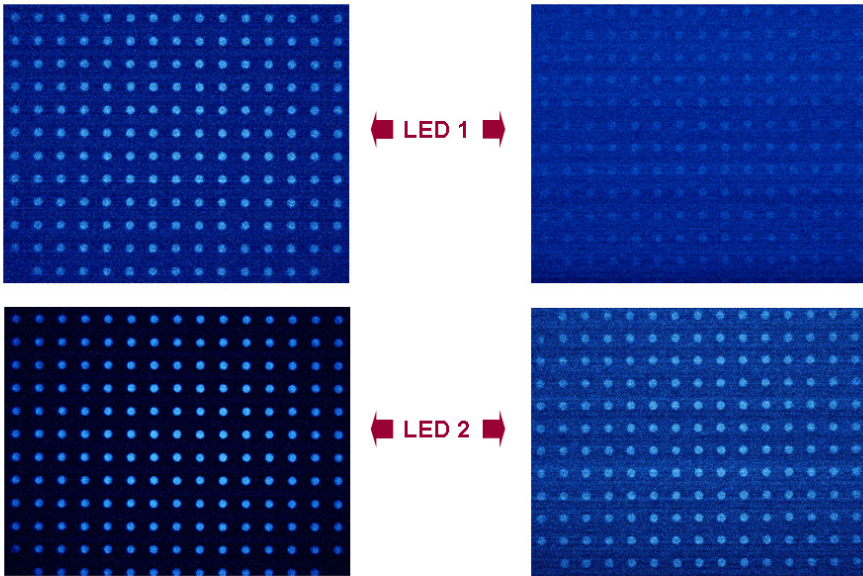

Figure 3. Schematic Layout of sCMOS Column Level Amplifiers and Analogue to Digital Converters (ADCs).

sCMOS ($1.5 e^-$ noise)

Interline CCD ($5 e^-$ noise)

Figure 5: Comparative low light images taken with sCMOS (1.5 electrons read noise @ 400MHz) vs interline CCD (5 electrons read noise @ 20MHz), under the two weakest LED intensities.



sCMOS

Interline CCD

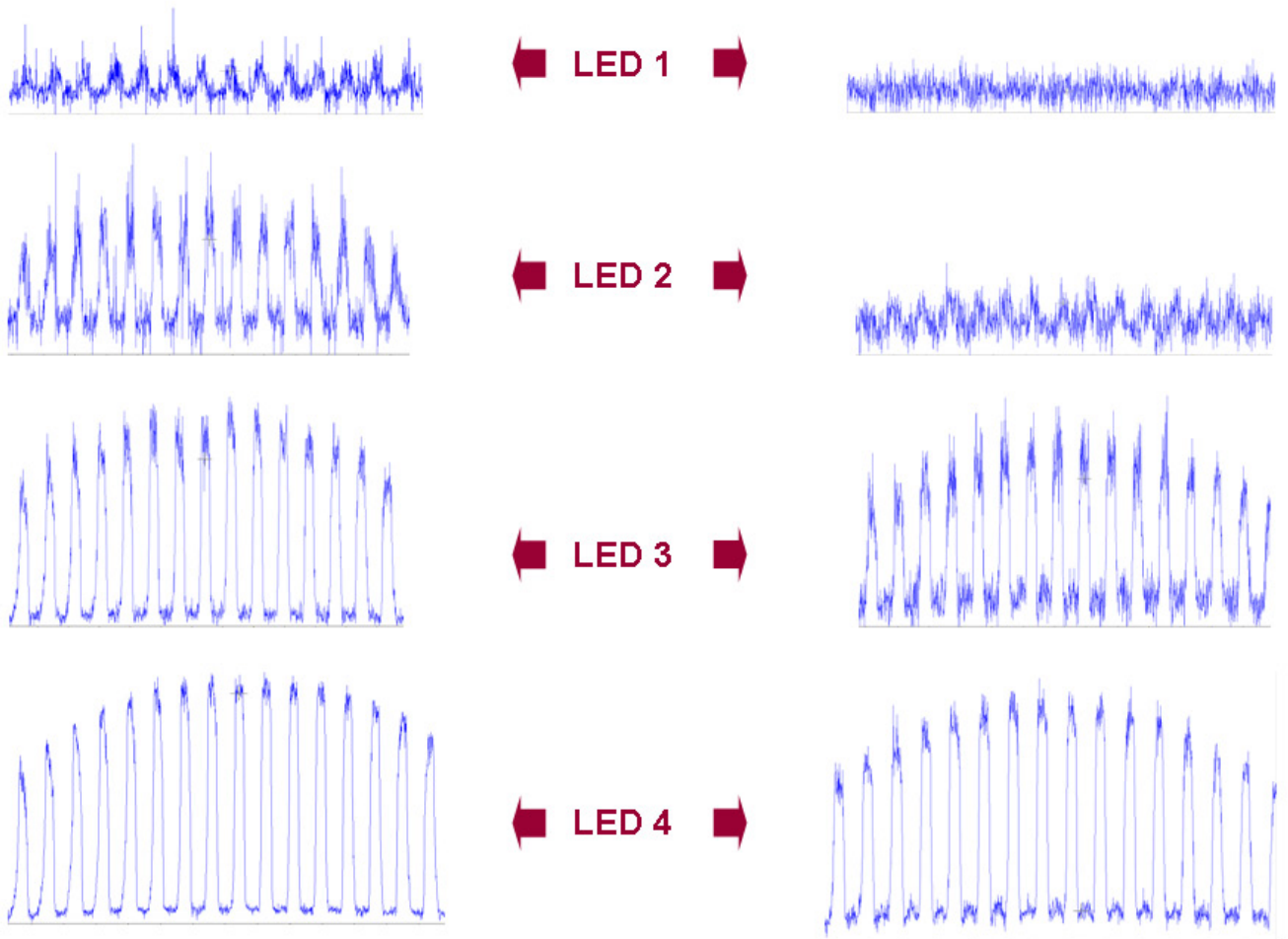

Figure 6: Intensity line profiles derived from LED images captured by sCMOS and interline CCD technology, for a range of LED intensities.

2.4 - Rolling vs Global (Snapshot) shutter modes

CMOS imagers read out in either *Rolling Shutter* or *Global Shutter* mode.

Rolling shutter essentially means that different lines of the array are exposed at different times as the read out ‘wave’ sweeps down through the sensor. Global shutter mode, which can also be thought of as a ‘snapshot’ exposure mode, means that all pixels of the array are exposed simultaneously. *With sCMOS technology has come the capability to offer both readout modes from the same sensor, such that the most appropriate mode can be selected dependent on application requirements.*

The global shutter mode carries the trade-off of halving the frame rate that would otherwise have been achieved in rolling shutter mode. In addition global shutter also increases the RMS read noise by a factor of 1.41 over rolling shutter readout.

The downside of rolling shutter, spatial distortion, has historically been more apparent in devices such as CMOS camcorders, where the entire image field could be moved (for example by the user rapidly panning the camera) at a rate that the image readout could not match; thus, objects could appear at an angle compared to their actual orientation.

Whether rolling shutter or global shutter is right for you will depend very much on the experiment. Rolling shutter mode, with the enhanced frame rates it enables, is likely to suit the majority of scientific applications. As long as the frame rate is such that the camera is temporally oversampling object dynamics, negligible spatial distortion will be observed. Such oversampling is good imaging practice, since it is undesirable to have an object travel a significant distance during a single exposure. This same tenet holds true for global shutter mode or any other method of controlling exposure time. For some particular applications however, such as in machine vision, global shutter mode will be viewed as a necessity.

2.5 - sCMOS compared to other leading scientific imaging technologies

A short comparative overview of sCMOS is provided in Table 2 below. For the purposes of this exercise, we limited the comparison to interline CCD and EMCCD technologies, given their popularity across the range of scientific imaging applications. Interline CCDs are typified by a choice of 1.3 megapixel or 4 megapixel sensors. The most popular EMCCD sensors are 0.25 or 1 megapixel, typically offering up to 30 frames/s.

It is apparent that across most parameters, sCMOS presents a distinct performance advantage, notably in terms of noise, speed, dynamic range and field of view/resolution.

Importantly, these advantages are met largely without compromise. Whilst the read noise of sCMOS is very low, EMCCD technology still maintains the distinct advantage of being able to multiply the input signal above the read noise floor, thus rendering it negligible ($<1 e^-$). The majority of EMCCD cameras purchased at this time are also of back-illuminated format, having $\sim 90\% QE_{max}$, which also feeds into the sensitivity comparison. For this reason, EMCCD technology will still hold firm in extreme low-light applications that require this level of raw sensitivity, and are willing to sacrifice on the enhanced resolution, field of view, dynamic range and frame rate that sCMOS can offer.

Parameter	sCMOS	Interline CCD	EMCCD
Sensor Format	5.5 megapixel	1.3 to 4 megapixel	0.25 to 1 megapixel
Pixel Size	6.5 μm	6.45 to 7.4 μm	8 to 16 μm
Read Noise	$< 2 e^-$ @ 30 frames/s	$4 - 10 e^-$	$< 1e^-$ (with EM gain)
Full Frame Rate (maximum)	100 frames/s @ full resolution	3 to 16 frames/s	~ 30 frames/s
Quantum Efficiency (QE)	60%	65%	90% ‘back-illuminated’ 65 % ‘virtual phase’
Dynamic Range	$> 16,000:1$ (@ 30 frames/s)	$\sim 3,000:1$ (@ 11 frames/s)	8500:1 (@ 30 frames/s with low EM gain)
Multiplicative Noise	None	None	1.41x with EM gain (effectively halves the QE)

Table 2 - Comparison summary of typical specifications of Interline CCD and EMCCD technologies compared to sCMOS technology.

Figures 5 to 11 show the results of head to head comparisons, pitching a prototype 5.5 Megapixel sCMOS camera against a 1.3 megapixel interline CCD device, and also against 1 Megapixel back-illuminated EMCCD. The sCMOS was set up to image at 400MHz, at this readout speed achieving 70 full frames/s, with only 1.5 electrons read noise. The interline CCD camera, an Andor 'Clara', was read out at 20MHz, achieving 11 frames/s with 5 electrons read noise (representing extreme optimization of this sensor at this speed). The EMCCD

camera, an Andor iXon^{EM+} 888, was read out at 10MHz with x300 EM gain amplification, achieving 9 frames/s with 0.15 electrons effective read noise. Low light imaging conditions were created using (a) a light tight imaging rig, fitted with a diffuse, intensity-variable 622 nm LED light source and mask overlay (consisting of either an array of holes or a USAF resolution chart), and (b) a widefield fluorescence microscope imaging fixed bovine epithelial cells, labeled with BODIPY FL (emission max. ~ 510nm).

The LED rig proved excellent for comparing sensitivity under extreme low light conditions, using a series of LED intensity settings, labeled 'LED1' through to 'LED4'. The photon flux intensities at each setting, given as photons per 6.5 μ m pixel, are approximately as follows: LED1 ~ 10 photons/pix; LED2 ~ 32 photons/pix; LED3 ~ 240 photons/pix; LED4 ~ 1050 photons/pix.

The SNR superiority of sCMOS over even well-optimized interline CCD technology can clearly be observed, manifest as better contrast of signal against a less noisy read noise background, resulting also in better resolution of features.

However, comparison of the two technologies against back-illuminated EMCCD (figure 8) at the weakest LED setting, showed that the < 1 electron noise floor and higher QE of the EMCCD resulted in superior contrast of the weak signal from the noise floor.

The fluorescence microscope images, at both x60 and x100 magnifications, clearly reveal the markedly larger field of view capability of the 5.5 megapixel sCMOS sensor compared with that of the 1.3 Megapixel interline CCD. Since each sensor type has ~ 6.5 μ m pixel pitch, allowing for adequate Nyquist oversampling at the diffraction limit, it is unsurprising that each show virtually identical resolution of fine intracellular structure under brighter conditions.

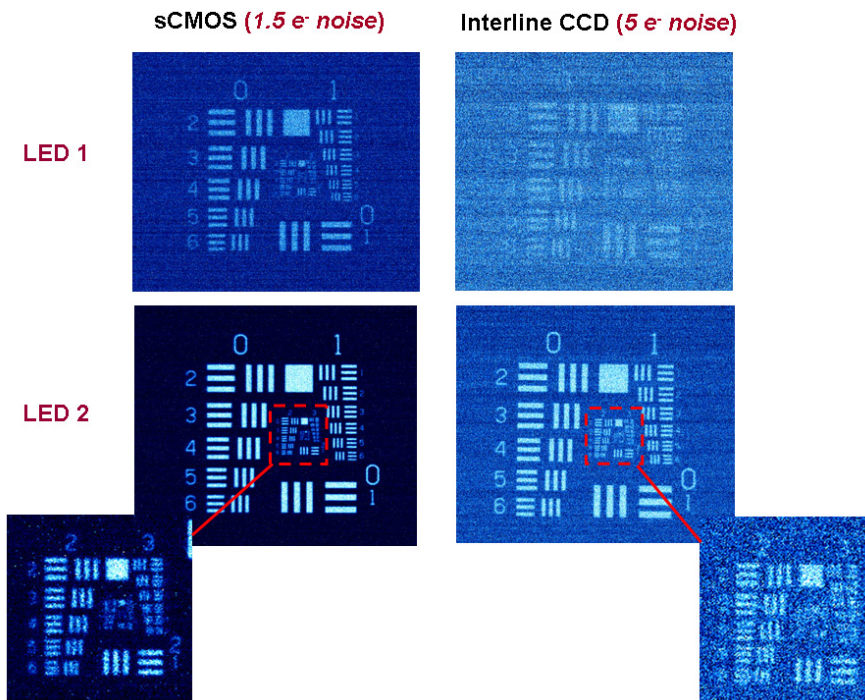

Figure 7: Comparative low light images of a USAF resolution chart, showing sCMOS (1.5 electrons read noise @ 400MHz) vs interline CCD (5 electrons read noise @ 20MHz), under the two lowest LED intensities.

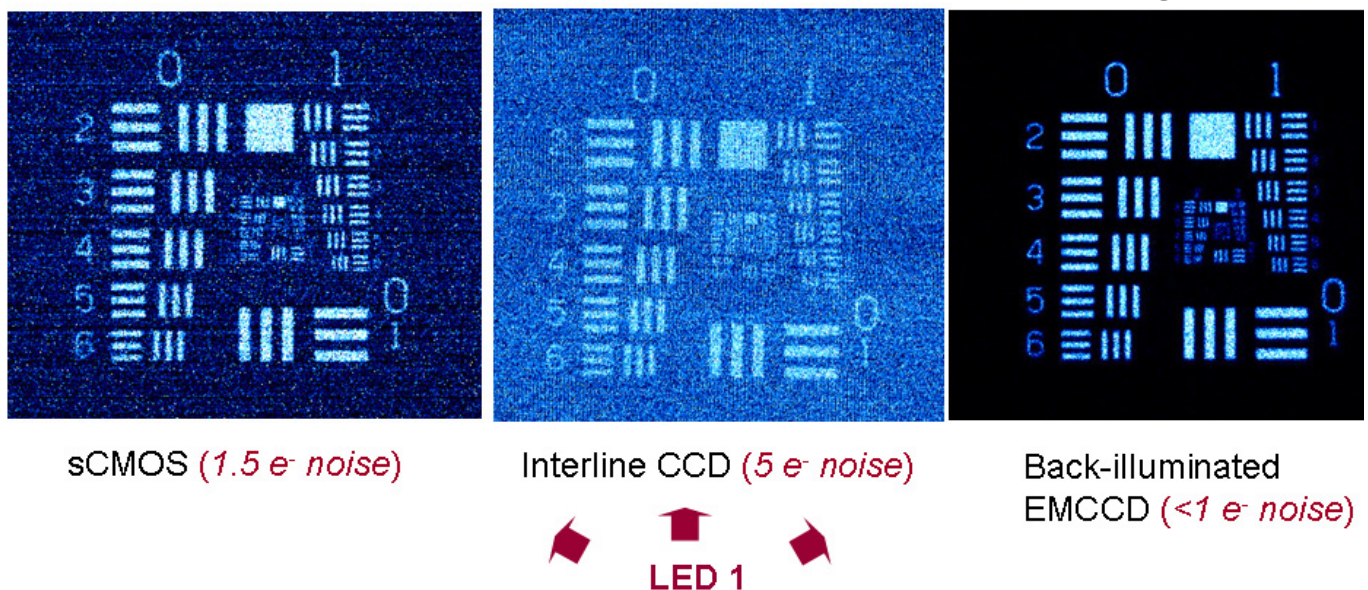
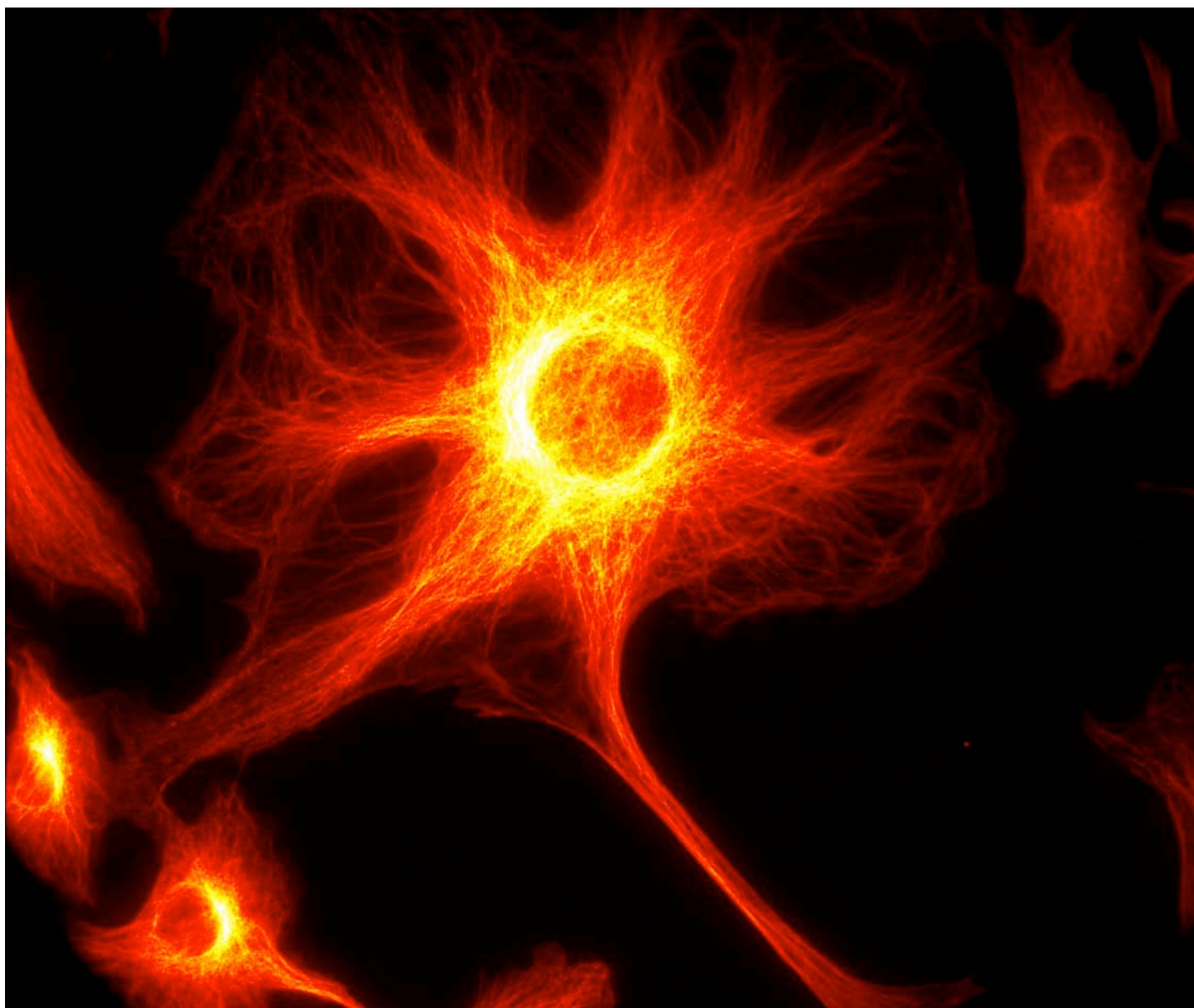

Figure 8: Comparative low light images taken with sCMOS (1.5 electrons read noise @ 400MHz) vs interline CCD (5 electrons read noise @ 20MHz) vs back-illuminated EMCCD (< 1e- read noise), under extremely low light conditions ('LED 1' setting). sCMOS and interline CCD were 2x2 binned in order to have the same effective pixel pitch (and light collection area per pixel) as the 13 μ m pixel of the EMCCD sensor.

5.5 Megapixel sCMOS



1.3 Megapixel Interline CCD

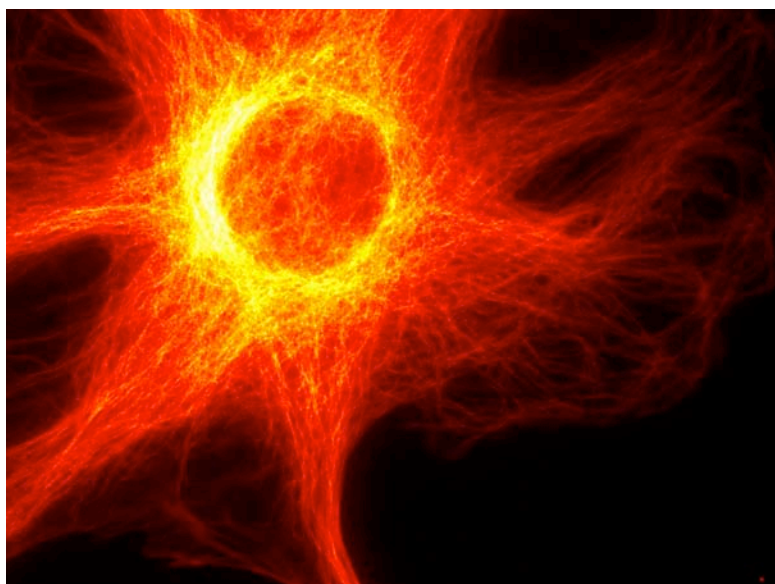
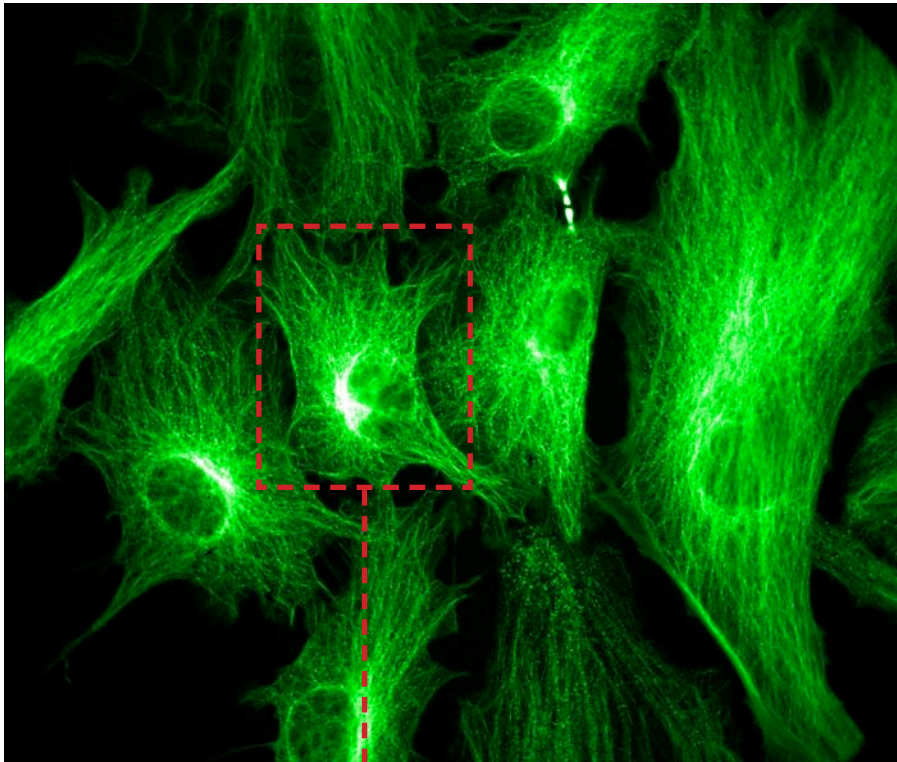

Figure 9: Field of view comparison of two technologies; x60 magnification; 1.25 NA; 5.5 megapixel sCMOS vs 1.3 megapixel interline CCD (each have $\sim 6.5 \mu\text{m}$ pixel pitch). sCMOS is capable of offering this larger field of view @ 100 frame/s with $< 3 e^-$ read noise.

5.5 Megapixel sCMOS



1.3 Megapixel Interline CCD

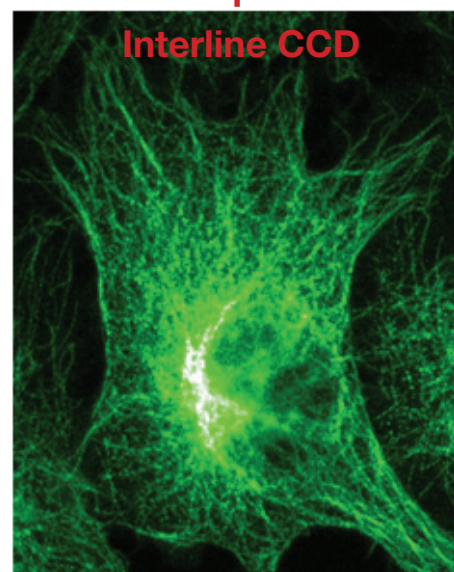
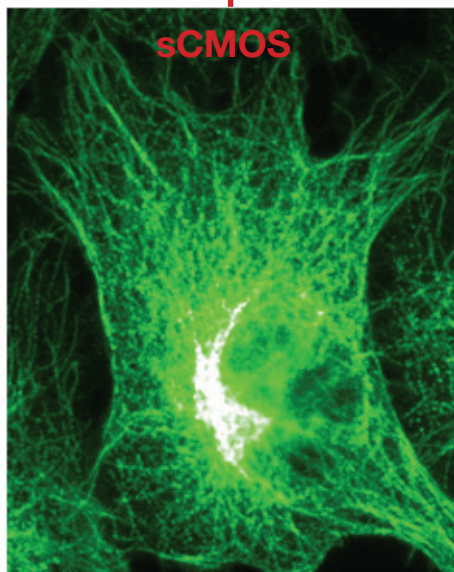
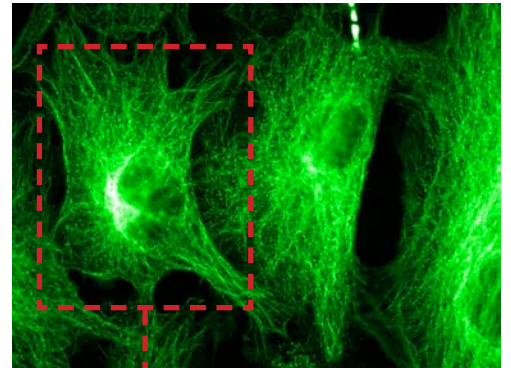

Figure 10: Field of view and resolution comparison of two technologies; x100 magnification; 1.45 NA; 5.5 megapixel sCMOS vs 1.3 megapixel interline CCD (each have ~ 6.5 μm pixel pitch). sCMOS is capable of offering this larger field of view @ 100 frame/s with $< 3 e^-$ read noise.

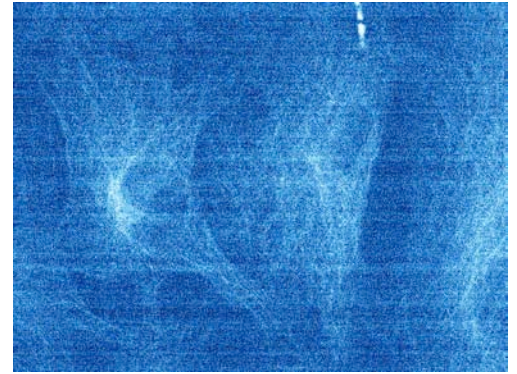
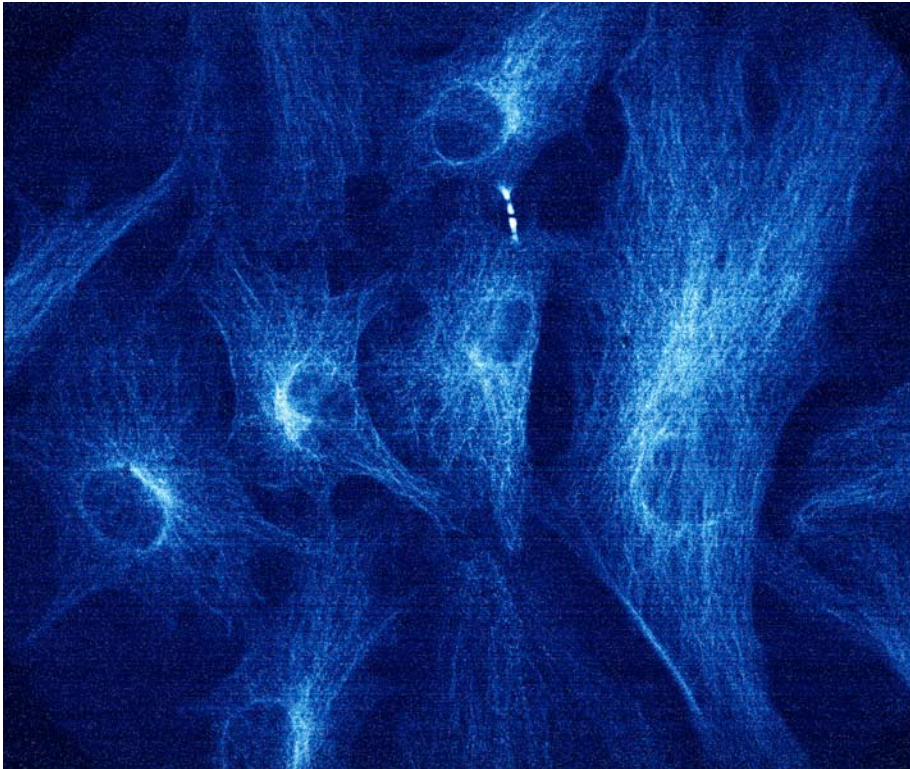

Figure 11: Comparative low light fluorescence microscopy images taken with sCMOS vs interline CCD under conditions typical of those employed in dynamic live cell imaging. ND filters on a widefield fluorescence microscope were used to reduce light levels relative to the read noise floor. Note that sCMOS can deliver this improved field of view and SNR ratio at ~ 70 frames/s under the conditions used (400MHz pixel readout), vs 11 frames/s of the interline CCD.

At low photon fluxes however, typified in figure 11, the higher read noise of the interline device results in greater sacrifice in resolution and contrast. This is a decisive point for live cell measurements, which often necessitate the use of low illumination energies.

To further supplement the relative sensitivity performance of these imaging technologies, theoretical SNR plots that are representative of these three technologies are given in Figures 12 and 13. For this comparative exercise, specifications were used that reflect the most sensitive interline CCD and back-illuminated EMCCD sensors on the market today.

Figure 12 shows how the SNR of sCMOS compares to that of interline CCD across a range of photon fluxes (i.e. incident light intensities). The pixel size differences between the two sensor types is negligible, thus there is no need to further correct for differing areas of light collection per pixel. The sensitivity differences between the two technology types is reflected in the marked variance between the respective SNR curves at low to moderate photon fluxes.

At higher photon fluxes, there is no 'cross-over' point between sCMOS and interline CCD curves. Similar QE and pixel size ensures that the interline CCD will never surpass the SNR performance of sCMOS. In fact, due to the significantly lower read noise, the sCMOS exhibits markedly better signal-to-noise than the interline CCD until several hundred photons/pixel at which point the two curves merge as the read noise of both sensors becomes negligible compared to the shot noise.

Figure 13 shows SNR plots that compare sCMOS and interline CCD sensors with that of back-illuminated EMCCD sensors. The plot assumes that all three sensors have the same pixel size, which could effectively be the case if the ~ 6.5µm pixels of both the sCMOS and interline CCD sensors were to be operated with 2x2 pixel binning, to equal a 13µm EMCCD pixel (representative of a popular back-illuminated EMCCD sensor on the market).

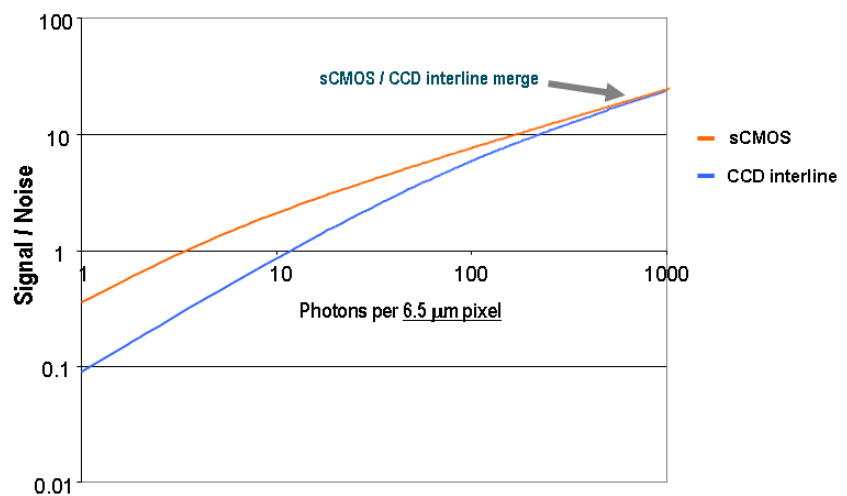

Figure 12 - Theoretical Signal to Noise plot comparisons for sCMOS vs interline CCD sensors. Photon flux (i.e. input light intensity) is given in terms of photons per 6.5µm pixel of each sensor type.

As such, the photon flux is presented in terms of photons per 13 μm pixel (or 2x2 binned super-pixel), relating to an actual pixel area of 169 μm^2 . There are two notable cross-over points of interest, relating to where the EMCCD S/N curve crosses both the sCMOS and interline CCD curves, which occur at photon flux values of ~ 48 photons/pixel and ~ 225 photons/pixel, respectively. At photon fluxes lower than these cross-over points the EMCCD delivers better S/N ratio, and worse S/N ratio at higher photon fluxes.

The reason that a back-illuminated EMCCD with negligible read noise does not exhibit higher S/N right throughout the photon flux scale, is due to the multiplicative noise of the EMCCD plot (which effectively increases the shot noise).

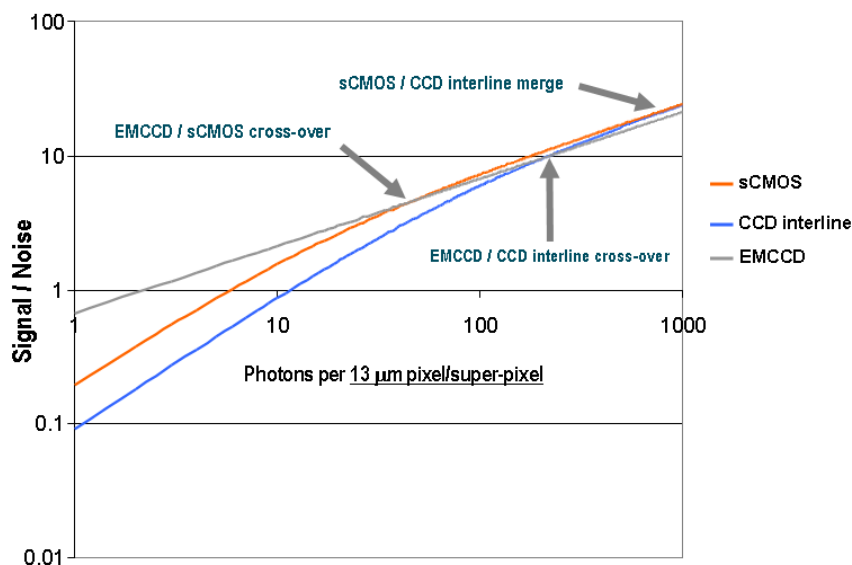

Figure 13 - Theoretical Signal to Noise plot comparisons for sCMOS vs interline CCD vs back-illuminated EMCCD sensors. For purposes of a objective comparison, it is assumed that the $\sim 6.5 \mu\text{m}$ pixels of the sCMOS and interline CCD sensors are 2x2 binned in order to equal a 13 μm pixel of a back-illuminated EMCCD.

Summary

After several decades of CIS maturation, we have now reached a ‘leap forward’ point, where we can confidently claim that the next significant wave of advancement in high-performance scientific imaging capability has come from the CIS technology stable.

Scientific CMOS (sCMOS) technology stands to gain widespread recognition across a broad gamut of demanding imaging applications, due to its distinctive ability to simultaneously deliver extremely low noise, fast frame rates, wide dynamic range, high quantum efficiency, high resolution and a large field of view.



Andor Technology plc
7 Millennium Way
Springvale Business Park
Belfast BT12 7AL
Northern Ireland

Tel: +44 (0)28 9023 7126
Fax: +44 (0)28 9031 0792
e-mail: marketing@andor.com



Fairchild Imaging
1801 McCarthy Blvd
Milpitas
CA 95035
USA

Tel: 1 (408) 433-2500
Fax: 1 (408) 435-7352
e-mail: sales@fcimg.com



PCO AG
Donaupark 11
93309 Kelheim
Germany

Tel: +49 (0)9441 2005 36
Fax: +49 (0)9441 2005 20
e-mail: info@pco.de